



**GEDA USA, LLC**

1151 Butler Rd. • League City, TX 77573

Phone: 713-621-7272 • Fax: 713-621-7279 • Toll-Free: 1-866-973-4332

[www.gedausa.com](http://www.gedausa.com) • [sales@gedausa.com](mailto:sales@gedausa.com)



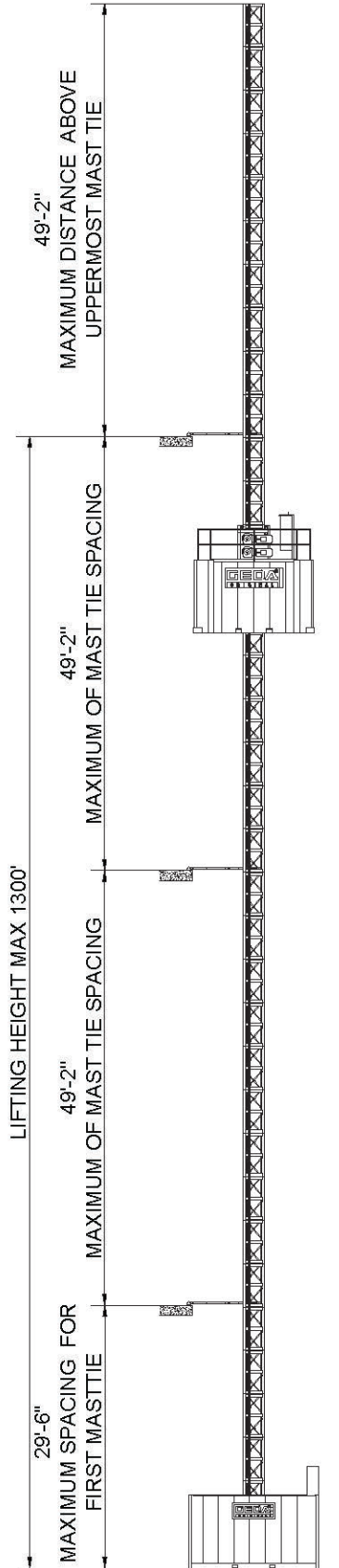

**ELEVATION VIEW**

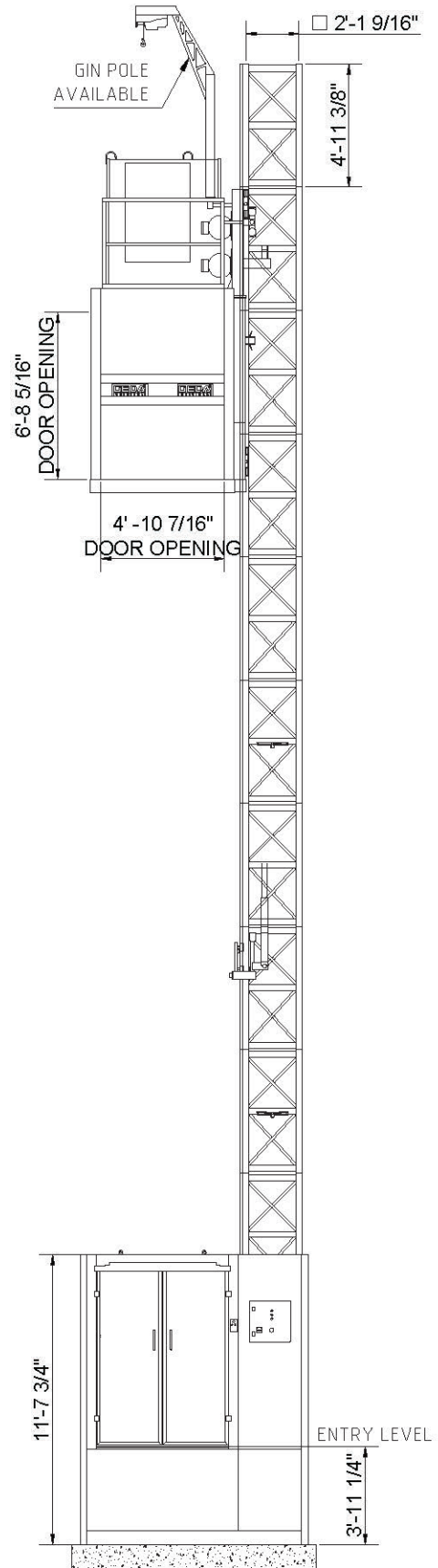

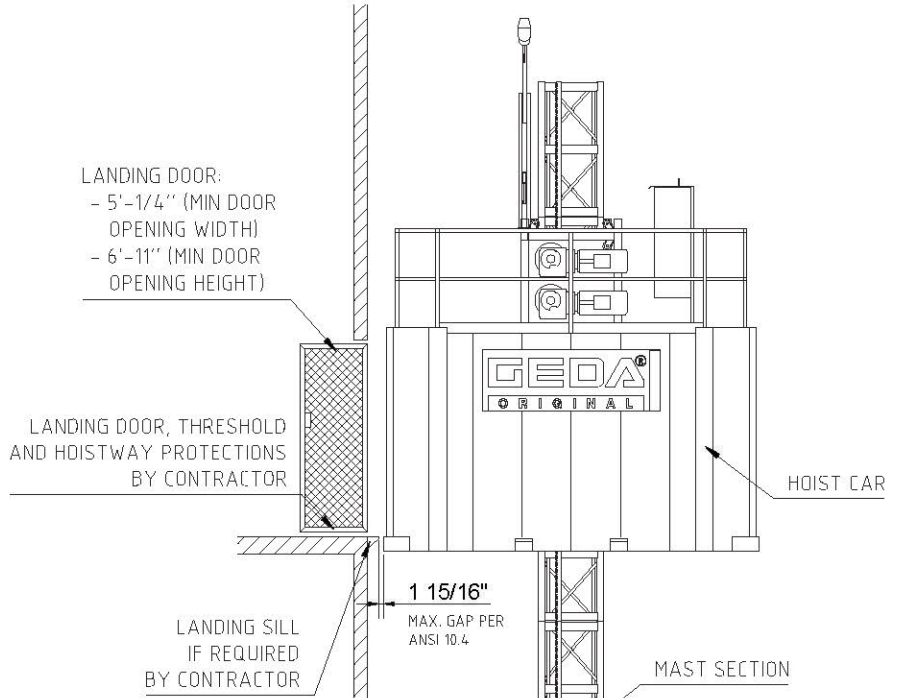

## DIMENSIONS CAR

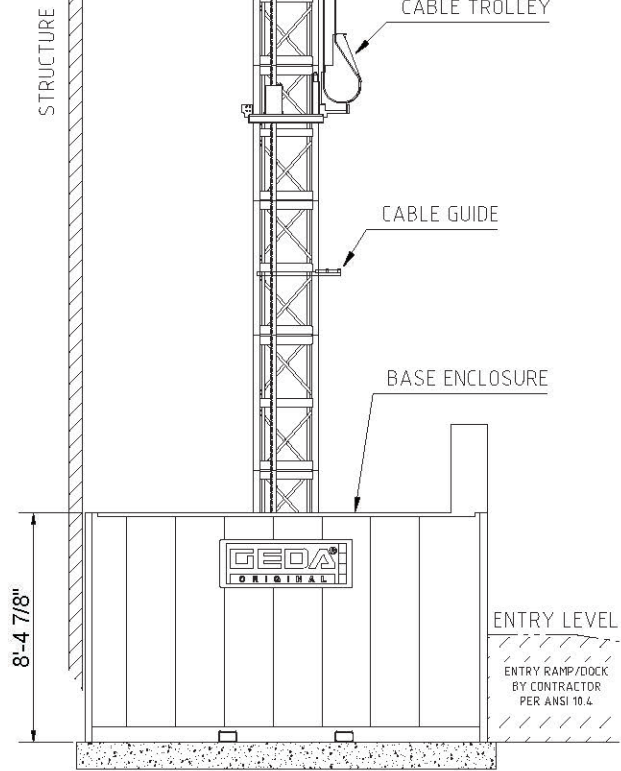
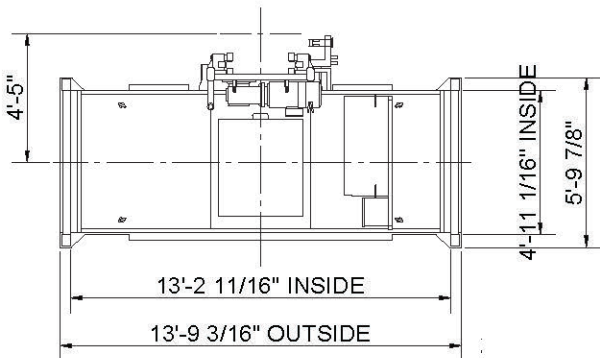
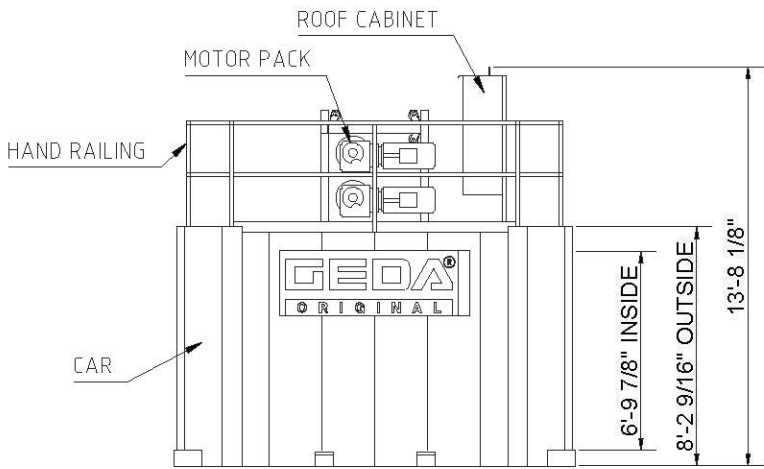

## TIE IN DETAILS - SLAB MOUNTED

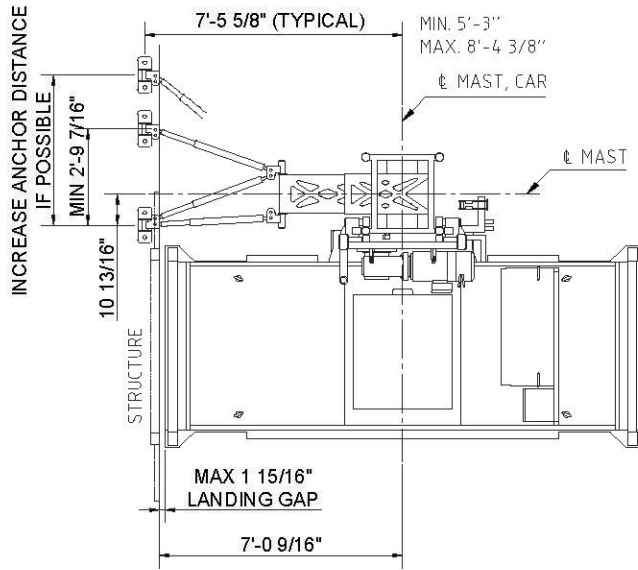

**ELEVATION VIEW**

## TIE IN DETAILS - SLAB MOUNTED WITH LANDING SILL

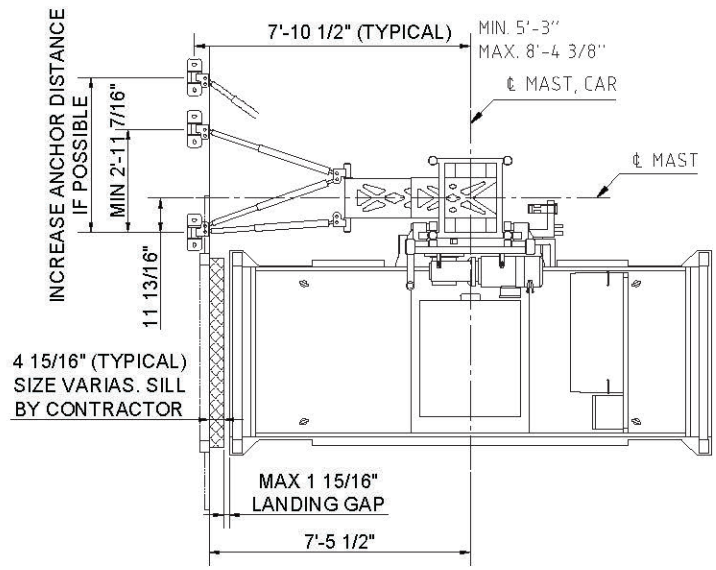

**INCLINATION DETAILS**

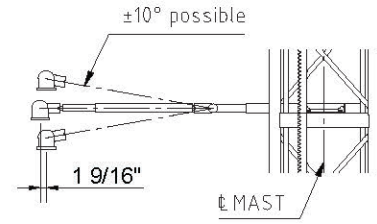
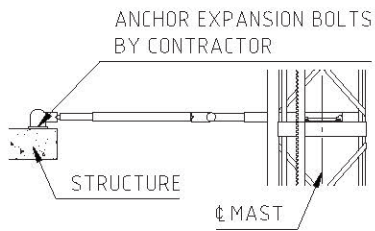

## TIE IN PLATE

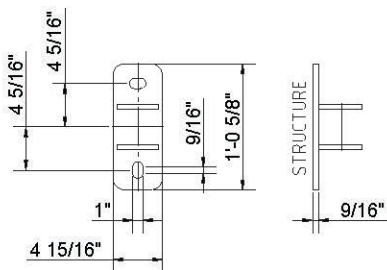

## ATTACHMENT POINTS

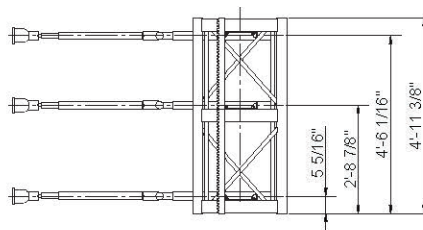

## TIE IN LOADS

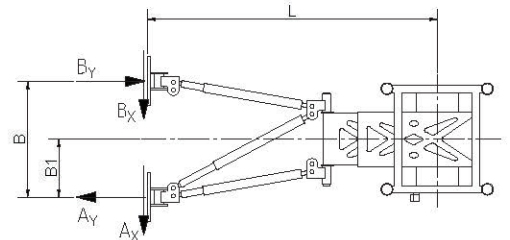

PLEASE SEE GEDA INSTALLATION MANUAL FOR TIE IN LOADS

ALTERNATE MAST TIES OR ANCHORING DISTANCES AVAILABLE. CONTACT GEDA FOR INFORMATION.

## TIE IN DETAILS - WALL MOUNTED

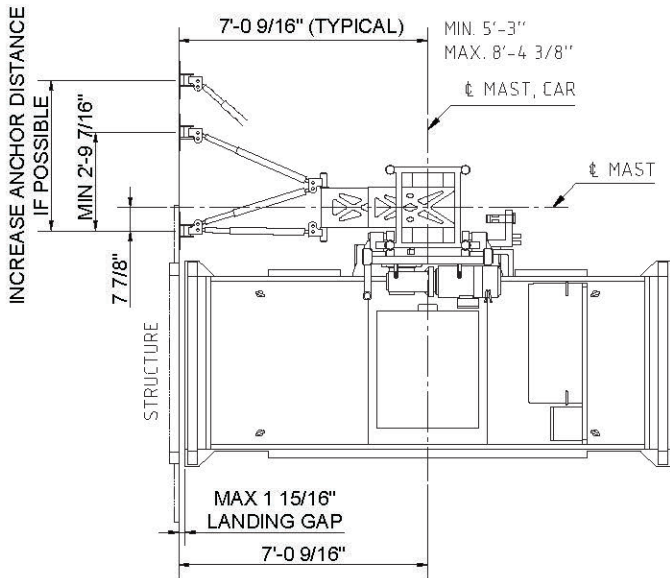

**ELEVATION VIEW**

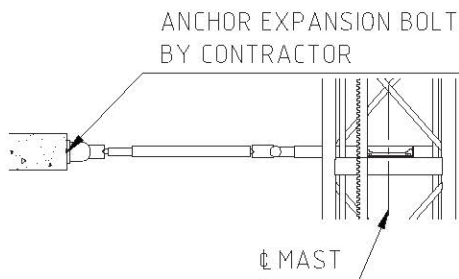

## TIE IN DETAILS - WALL MOUNTED WITH LANDING SILL

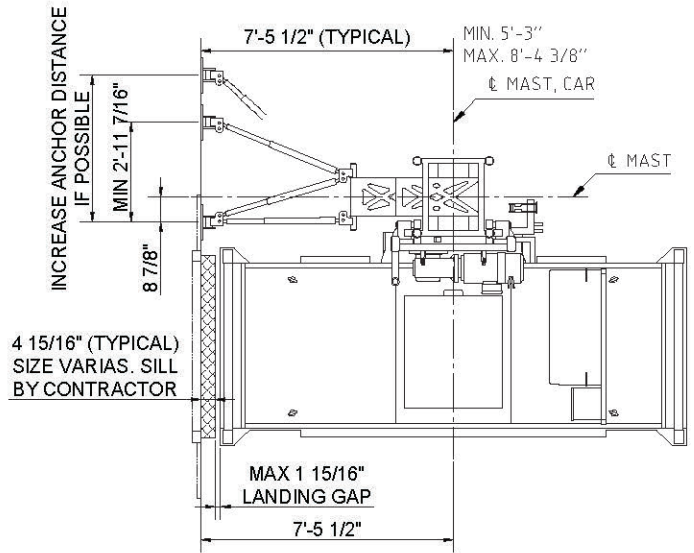

**INCLINATION DETAILS**

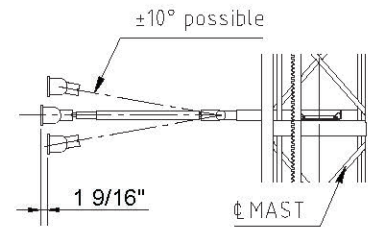

## PLAN VIEW BASE ENCLOSURE

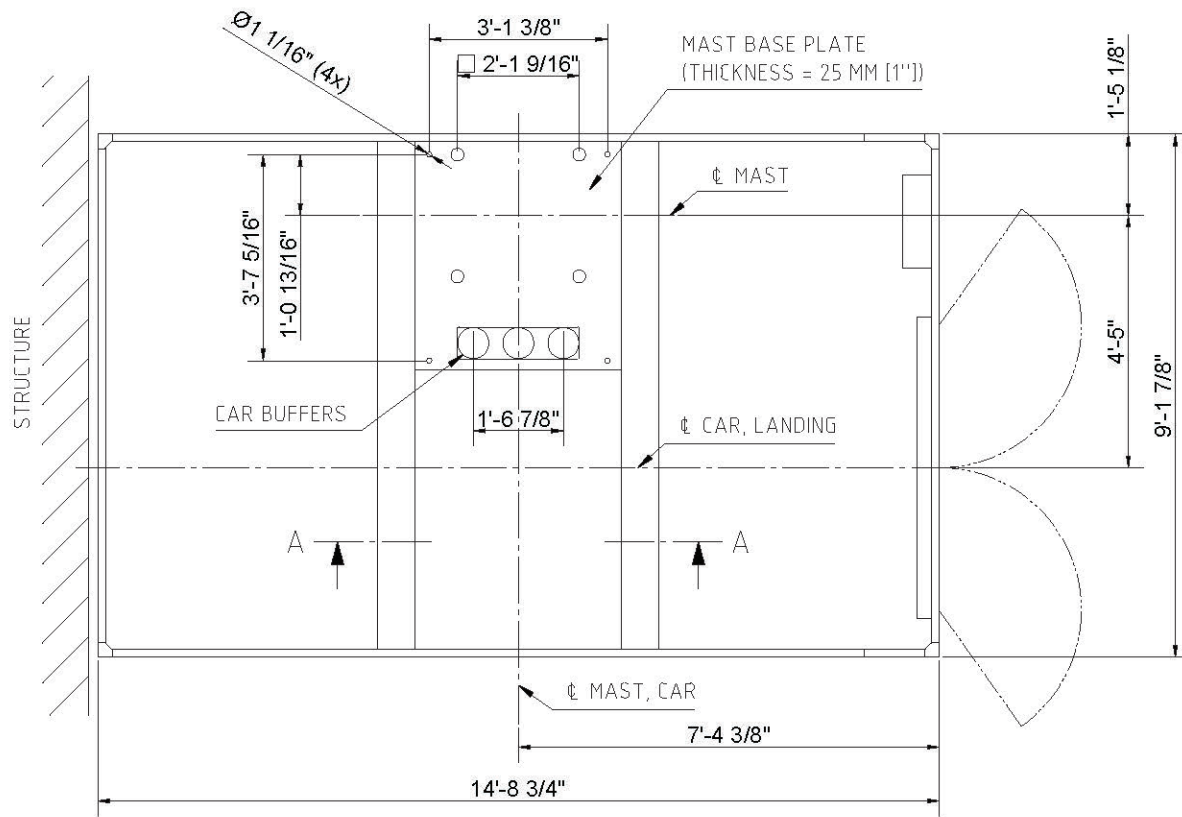

## MAST BASE

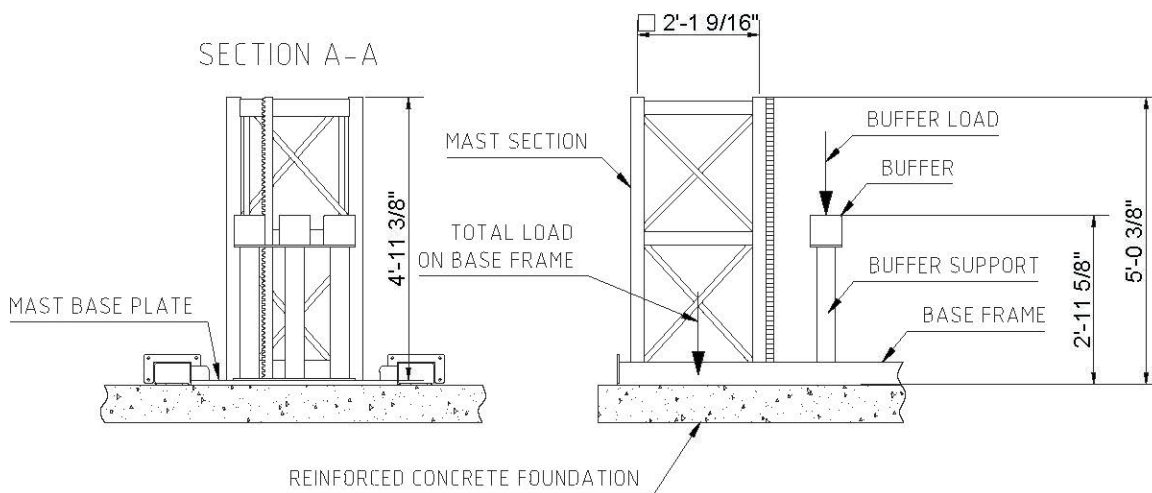

PLEASE SEE GEDA INSTALLATION MANUAL FOR TOTAL LOAD ON BASE FRAME AND BUFFER LOAD.

## FOUNDATION PLAN VIEW

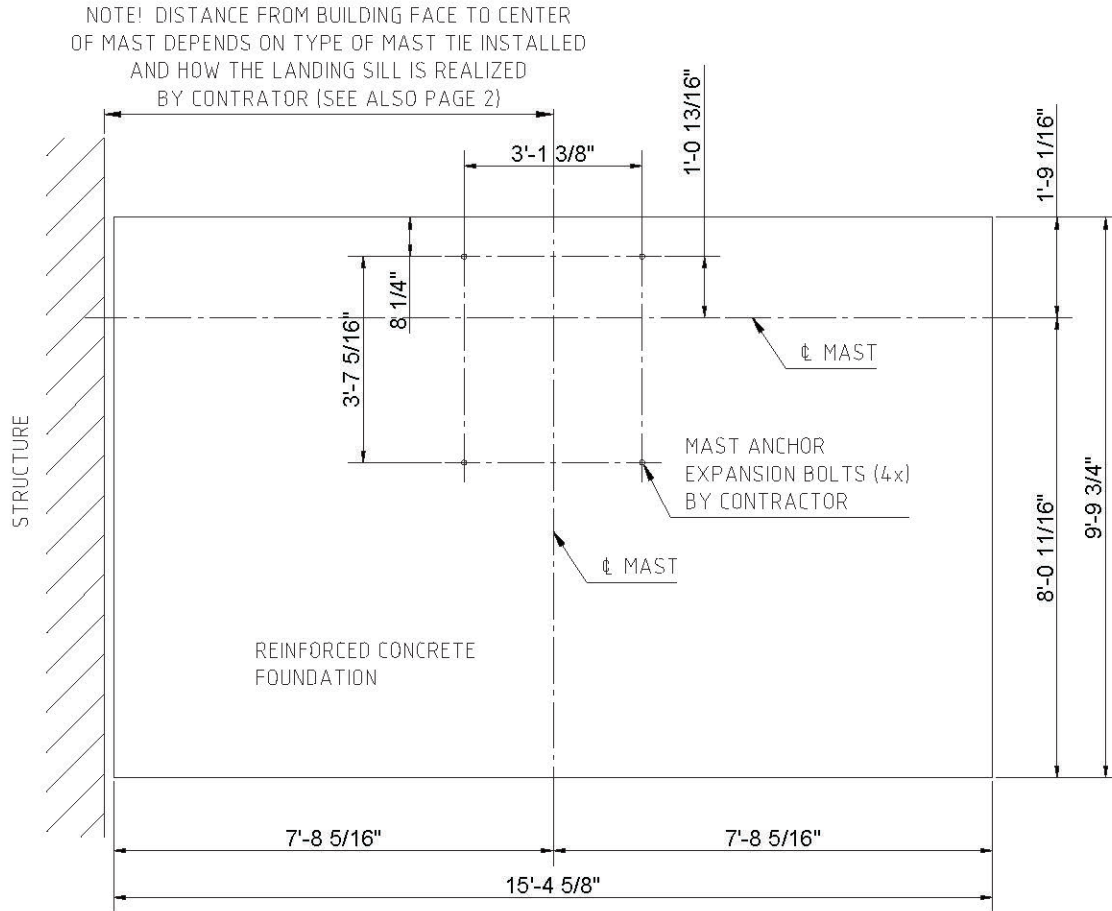

## FOUNDATION SIDE VIEW

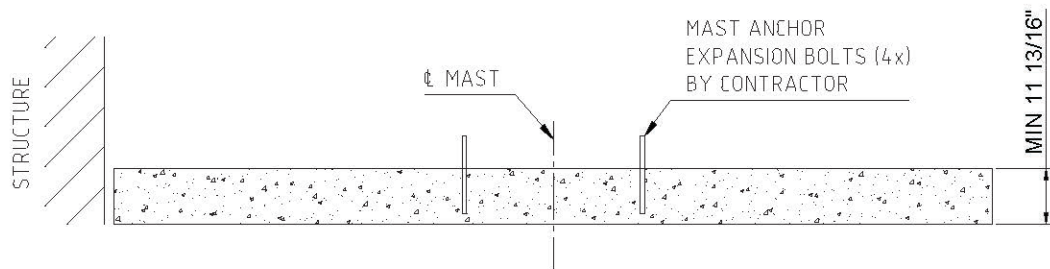



## SPECIFICATIONS

### MACHINE TECHNICAL DATA SPECS

MACHINE TYPE:	GEDA PH7000
CONFIGURATION:	SINGLE, LEFT CAR
CAPACITY:	7000 POUNDS
LIFTING HEIGHT:	VARIABLE (MAX 400m)
RATED SPEED:	131 ft/min.
NUMBER OF MOTORS:	2x19 kW (105 Hz)
MOTOR PACK TYPE:	VFC

### COMPONENTS WEIGHT

BASE ENCLOSURE:	3100 LBS
CAR:	3980 LBS
MOTORPACK:	1650 LBS
ROOF CABINET:	575 LBS
MAST SECTION SINGLE:	343 LBS
MAST TIE:	230 LBS
CABLE GUIDE	12.5 LBS
CABLE TROLLEY:	165 LBS

### POWER SUPPLY REQUIREMENTS (PER CAR)

VOLTAGE:	480 V, 3 PHASE	FREQUENCY:	60 HZ
MAINS FUSES:	63 A	POWER CONSUMPTION	55 kVA



Machinery Directive 2006/42/EG  
DIN EN ISO 9001:2008

